

# CINTRÉE



## MATERIALS

Bracket: mechanically welded aluminum.

## SURFACE TREATMENT

Baked (220°C) polyester powder coating.

RAL colors or structured paint optional.

## BRACKET/COLUMN JUNCTION

Adaptable bracket on Ø60 to 76mm columns (interior Ø48.5mm minimum)

Sealing with column by integrated bracket cup

Fastening by pressure screws on the column

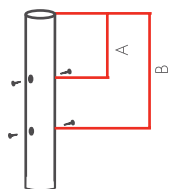

- A must be between 20 and 130 mm.
- B must be between 165 and 480 mm.

10° TILT (5° AVAILABLE ON REQUEST)

## BRACKET/LUMINAIRE JUNCTION

Ø60mm on-sliding sleeve mounting

## MURAL BRACKET MOUNTING

2 Ø14mm holes, inter-axial distance 220mm

## OFFSET LIGHT BRACKET MOUNTING

2 supplied M12 screws, inter-axial distance 220mm

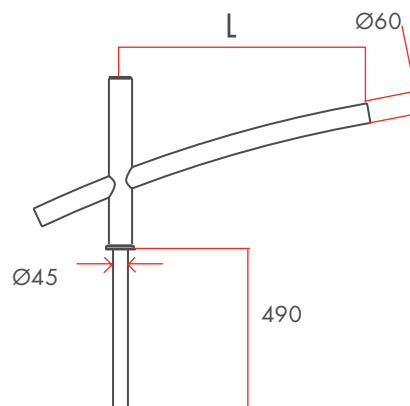

• CINTRÉE SINGLE LIGHT

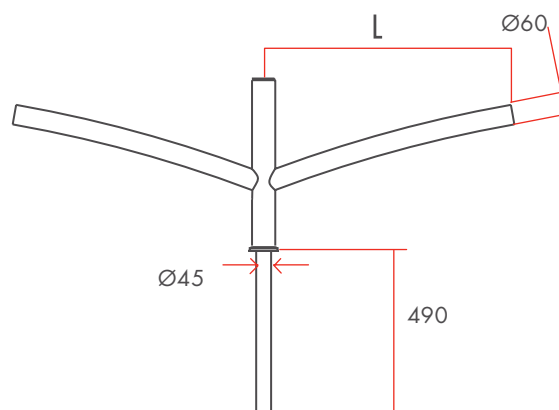

• CINTRÉE DOUBLE LIGHTS

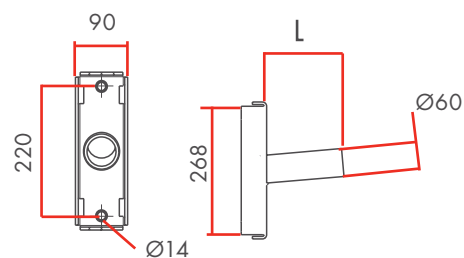

• CINTRÉE WALL AND OFFSET LIGHTS

	L mm	WEIGHT kg	S C X m <sup>2</sup>
SINGLE LIGHT	750	4,8	0,07
	1200	5,4	0,12
DOUBLE LIGHTS	750	6,9	0,14
	1200	7,8	0,24
MURAL	200	1	0,03
	500	1,7	0,05
OFFSET LIGHT	200	1	0,03
	500	1,7	0,05