

# MONA



## MATERIALS

Bracket: single, double light and mural lights in die cast and mechanically welded aluminum

## SURFACE TREATMENT

Black, sanded 2100 color or other RAL hue optional  
Baked (220°C) polyester powder coating

## BRACKET/COLUMN JUNCTION

Adaptable bracket solely on Ø76mm columns  
Sealing with column by joint  
Fastening by pressure screws on the column

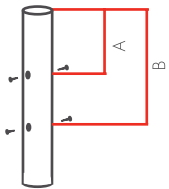

- A must be between 20 and 130 mm.
- B must be between 200 and 230 mm.

5° TILT

## BRACKET/LUMINAIRE JUNCTION

Tubular lateral mounting Ø60-62mm

**Bracket designed for ORKANE luminaire**

## WALL AND OFFSET LIGHTS BRACKET MOUNTING

2 Ø14mm holes

Inter-axial distance 190mm

	L mm	WEIGHT kg	S C X m <sup>2</sup>
SINGLE LIGHT	250	3,9	0,05
	1000	8,4	0,11
DOUBLE LIGHT	250	5,4	0,10
MURAL	65	1	0,01
	815	5,5	0,07

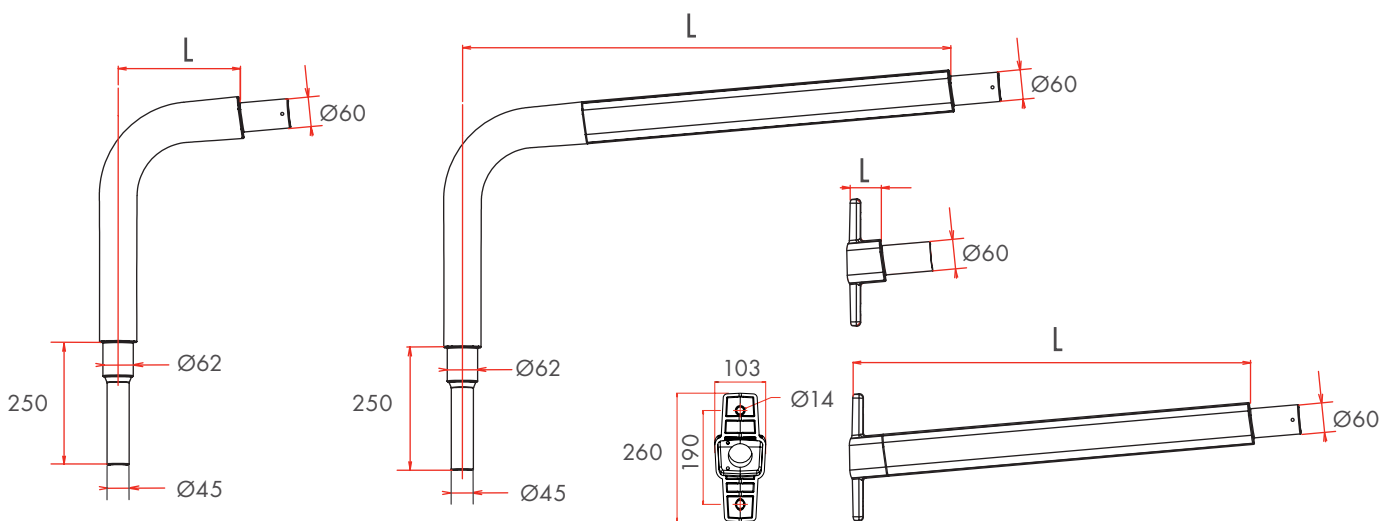

• MONA SINGLE LIGHT (ONLY IN LENGTH 250MM FOR DOUBLE LIGHTS)

• MONA MURAL