

SASKIA



MATERIALS

Bracket: mechanically welded aluminum

SURFACE TREATMENT

RAL hues, or structured paint optional
Baked (220°C) polyester powder coating

BRACKET/COLUMN JUNCTION

Adaptable bracket on Ø60 to 76mm (central Ø48.5mm minimum) columns

Sealing with column by integrated bracket cup

Fastening by pressure screws on the column

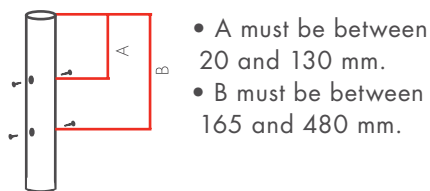

BRACKET/LUMINAIRE JUNCTION

Luminaire junction: gas screw 26x34 (1") tube section, depth 36mm

Bracket designed for **ROTHESAY** and **CILLA** luminaires

MURAL BRACKET MOUNTING

2 Ø14mm holes for 2 M12 screws

Inter-axial distance 220 mm

OFFSET LIGHT BRACKET MOUNTING

2 supplied M12 screws, Inter-axial distance 220 mm

	L mm	WEIGHT kg	S C X m ²
SINGLE LIGHT	750	5,5	0,08
	1000	7	0,10
	1500	7.4	0.12
DOUBLE LIGHTS	750	10	0,12
	1000	11	0,15
	1500	15	0,24
MURAL AND OFFSET LIGHTS	500	3,5	0,06
	750	4,5	0,07
	1200	6,0	0,08

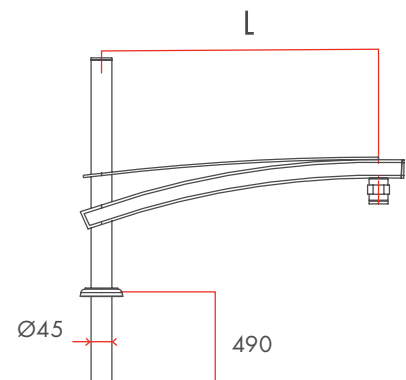

• **SASKIA SINGLE LIGHT**

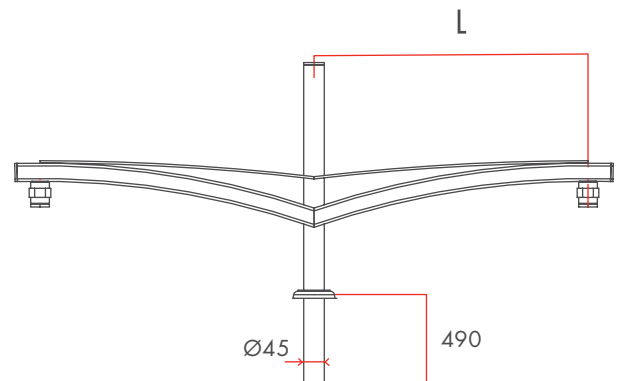

• **SASKIA DOUBLE LIGHTS**

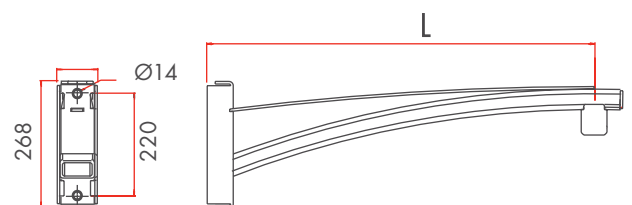

• **SASKIA MURAL AND OFFSET LIGHTS**