

MAGMA



MATERIALS

Bracket: mechanically welded aluminum

SURFACE TREATMENT

RAL hues, or structured paint optional
Baked (220°C) polyester powder coating

BRACKET/COLUMN JUNCTION

Adaptable bracket on $\varnothing 60$ to 76mm (interior $\varnothing 48.5$ mm minimum) columns

Sealing with column by integrated bracket cup
Fastening by pressure screws on the column

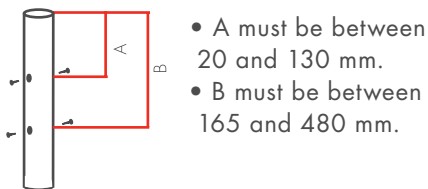

BRACKET/LUMINAIRE JUNCTION

$\varnothing 60$ mm covering sleeve mounting

MURAL BRACKET MOUNTING

2 $\varnothing 14$ mm holes
Inter-axial distance 260mm

OFFSET LIGHT BRACKET MOUNTING

2x supplied M12 screws
Inter-axial distance 260mm

	L mm	WEIGHT kg	S C X m ²
SINGLE LIGHT	600	3,3	0,12
DOUBLE LIGHTS	600	4,9	0,16
MURAL	500	2,11	0,06
OFFSET LIGHT	500	2,11	0,06

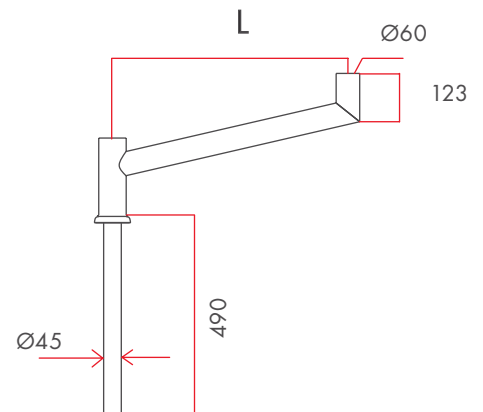

• MAGMA SINGLE LIGHT TOP MOUNTING

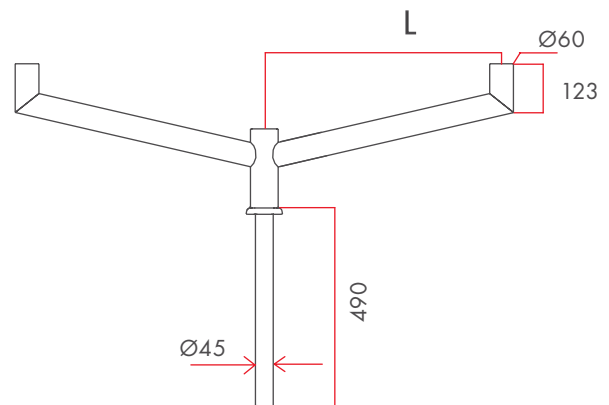

• MAGMA DOUBLE LIGHT TOP MOUNTING

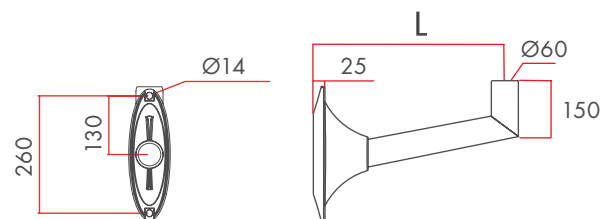

• MAGMA WALL AND OFFSET LIGHT